

PRO-FORM®

Le de TOUR FRANCE

Model No. PFEVEX71413.3

Serial No. _____

Write the serial number in the space above for reference.

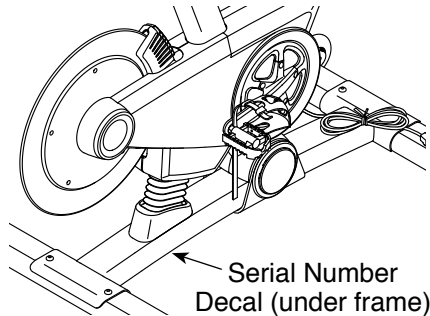

USER'S MANUAL

CUSTOMER SERVICE

UNITED KINGDOM

Call: 0330 123 1045

From Ireland: 053 92 36102

Website: www.iconsupport.eu

E-mail: csuk@iconeurope.com

Write:

ICON Health & Fitness, Ltd.

Unit 1D, The Gateway

Fryers Way, Silkwood Park

OSSETT

WF5 9TJ

UNITED KINGDOM

AUSTRALIA

Call: 1800 993 770

E-mail: australiacc@iconfitness.com

Write:

ICON Health & Fitness

PO Box 635

WINSTON HILLS NSW 2153

AUSTRALIA

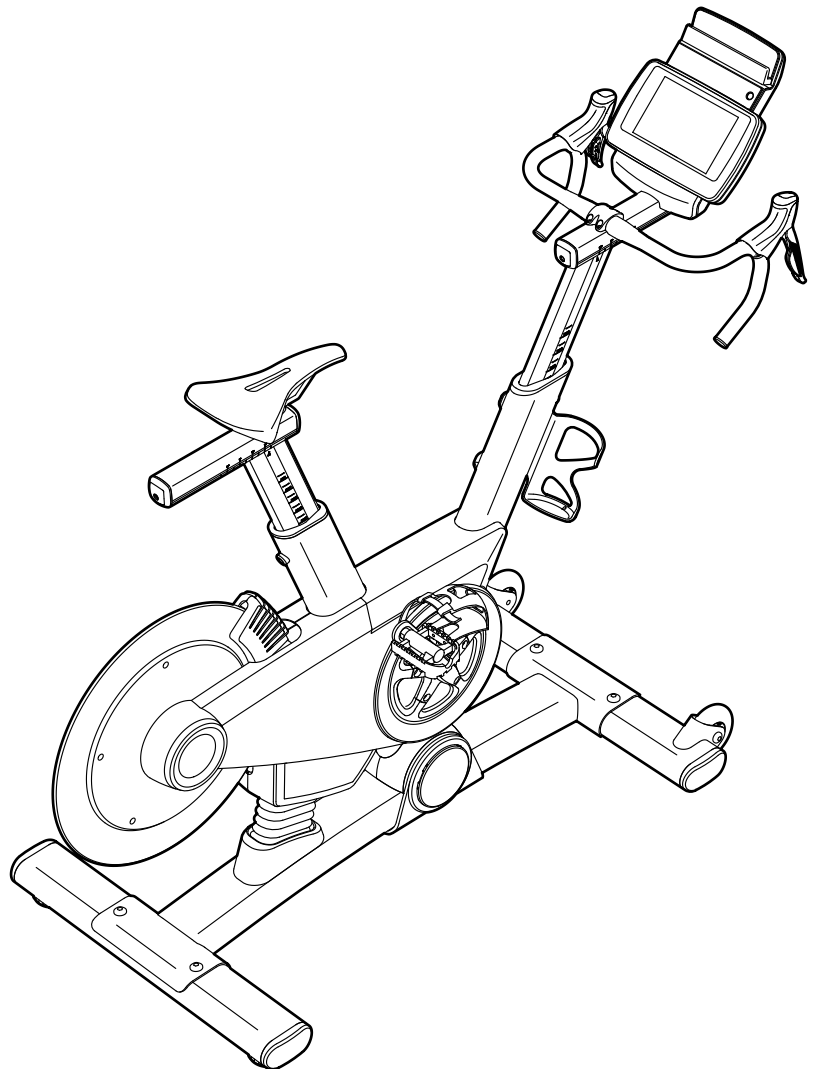

⚠ CAUTION

Read all precautions and instructions in this manual before using this equipment. Keep this manual for future reference.

www.iconeurope.com

TABLE OF CONTENTS

WARNING DECAL PLACEMENT 2

IMPORTANT PRECAUTIONS..... 3

BEFORE YOU BEGIN..... 4

PART IDENTIFICATION CHART..... 5

ASSEMBLY..... 6

HOW TO USE THE TRAINING BIKE 11

MAINTENANCE AND TROUBLESHOOTING..... 27

EXERCISE GUIDELINES 28

PART LIST..... 29

EXPLODED DRAWING..... 31

ORDERING REPLACEMENT PARTS..... Back Cover

RECYCLING INFORMATION Back Cover

WARNING DECAL PLACEMENT

This drawing shows the location(s) of the warning decal(s). **If a decal is missing or illegible, see the front cover of this manual and request a free replacement decal. Apply the decal in the location shown.** Note: The decal(s) may not be shown at actual size.

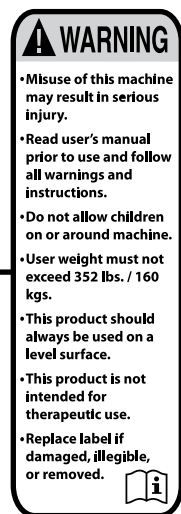
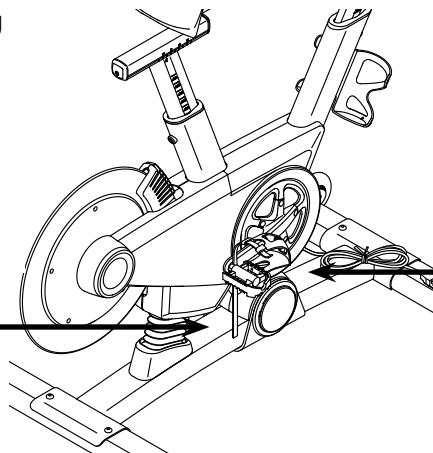

PROFORM is a registered trademark of ICON Health & Fitness, Inc. | LE TOUR DE FRANCE is a registered trademark of Société du Tour de France. | ANT+™ is a trademark of Garmin Ltd. or its subsidiaries. | The BLUETOOTH® word mark and logos are registered trademarks of Bluetooth SIG, Inc. and are used under license. | iPad is a trademark of Apple Computer, Inc., registered in the U.S. and other countries. iPad® is not included.

IMPORTANT PRECAUTIONS

⚠️ WARNING: To reduce the risk of burns, fire, electric shock, or injury to persons, read all important precautions and instructions in this manual and all warnings on your training bike before using your training bike. ICON assumes no responsibility for personal injury or property damage sustained by or through the use of this product.

1. It is the responsibility of the owner to ensure that all users of the training bike are adequately informed of all precautions.
2. Before beginning any exercise program, consult your physician. This is especially important for persons over age 35 or persons with pre-existing health problems.
3. Use the training bike only as described in this manual.
4. The training bike is intended for home use only. Do not use the training bike in a commercial, rental, or institutional setting.
5. Keep the training bike indoors, away from moisture and dust. Do not put the training bike in a garage or covered patio, or near water.
6. Place the training bike on a level surface with at least 2 ft. (0.6 m) of clearance around the training bike. To protect the floor or carpet from damage, place a mat under the training bike.
7. Inspect and properly tighten all parts regularly. Replace any worn parts immediately.
8. Keep children under age 12 and pets away from the training bike at all times.
9. When connecting the power cord, plug the power cord into a grounded circuit.
10. Do not modify the power cord or use an adapter to connect the power cord to an improper receptacle. Keep the power cord away from heated surfaces. Do not use an extension cord.
11. Do not operate the training bike if the power cord or plug is damaged, or if the training bike is not working properly.
12. **DANGER:** Always unplug the power cord and press the power switch to the off position when the training bike is not in use and before cleaning the training bike. Servicing other than the procedures in this manual should be performed by an authorized service representative only.
13. Wear appropriate clothes while exercising; do not wear loose clothes that could become caught on the training bike. Always wear athletic shoes for foot protection.
14. The training bike should not be used by persons weighing more than 352 lbs. (160 kg).
15. Be careful when mounting and dismounting the training bike.
16. Always keep your back straight while using the training bike; do not arch your back.
17. Over exercising may result in serious injury or death. If you feel faint or if you experience pain while exercising, stop immediately and cool down.

SAVE THESE INSTRUCTIONS

BEFORE YOU BEGIN

Congratulations for selecting the revolutionary PROFORM® LE TOUR DE FRANCE® training bike. The LE TOUR DE FRANCE training bike is unlike any ordinary exercise bike. With full adjustability, a Wi-Fi cycling console, an incline system that simulates actual road terrain, and an array of other innovative features, the LE TOUR DE FRANCE training bike is designed to let you enjoy the outdoor cycling experience indoors.

For your benefit, read this manual carefully before you use the training bike. If you have questions after

reading this manual, please see the front cover of this manual. To help us assist you, note the product model number and serial number before contacting us. The model number and the location of the serial number decal are shown on the front cover of this manual.

Before reading further, please familiarize yourself with the parts that are labeled in the drawing below.

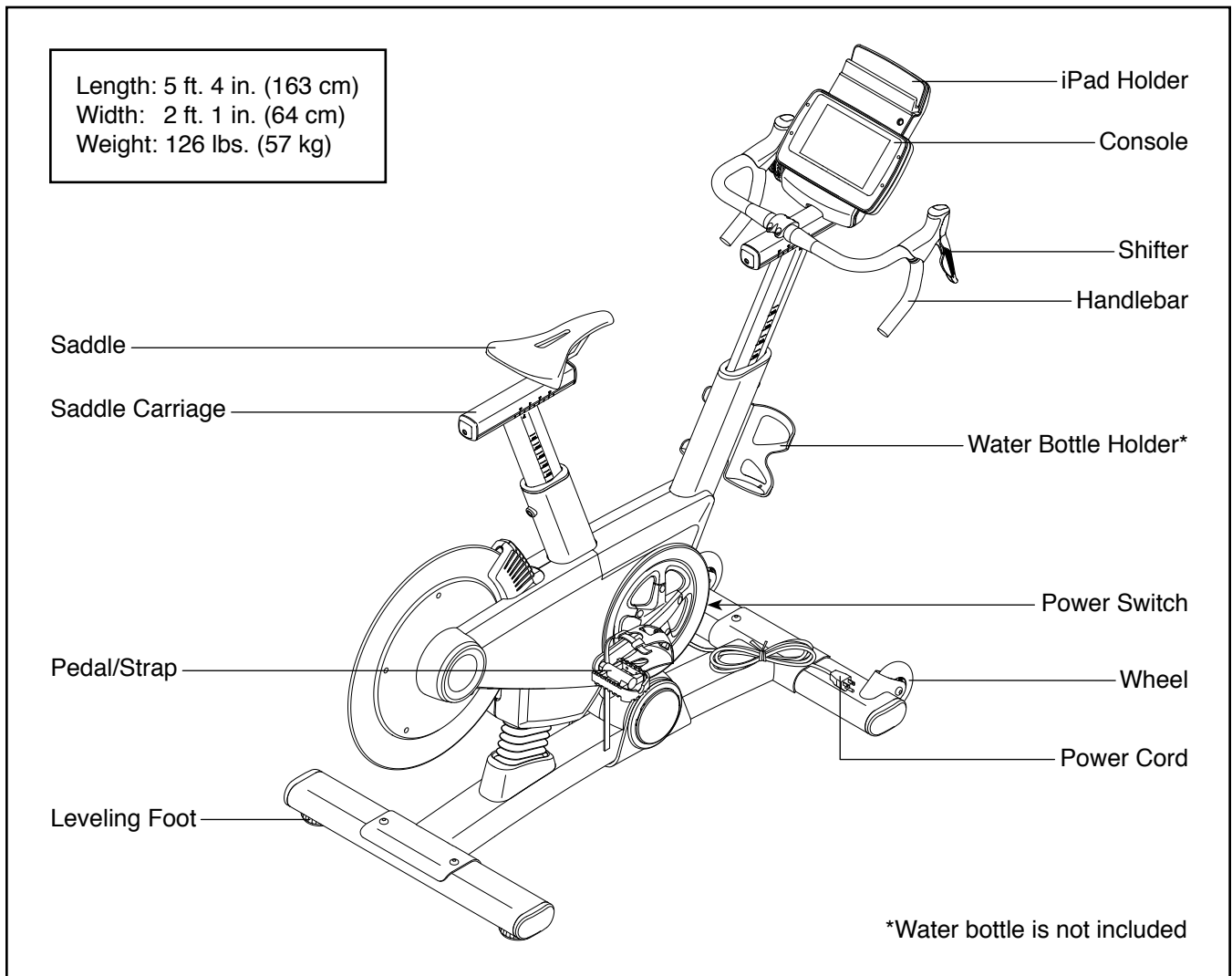

PART IDENTIFICATION CHART

Use the drawings below to identify the small parts needed for assembly. The number in parentheses below each drawing is the key number of the part, from the PART LIST near the end of this manual. The number following the key number is the quantity needed for assembly. **Note: If a part is not in the hardware kit, check to see if it has been preassembled. Extra parts may be included.**

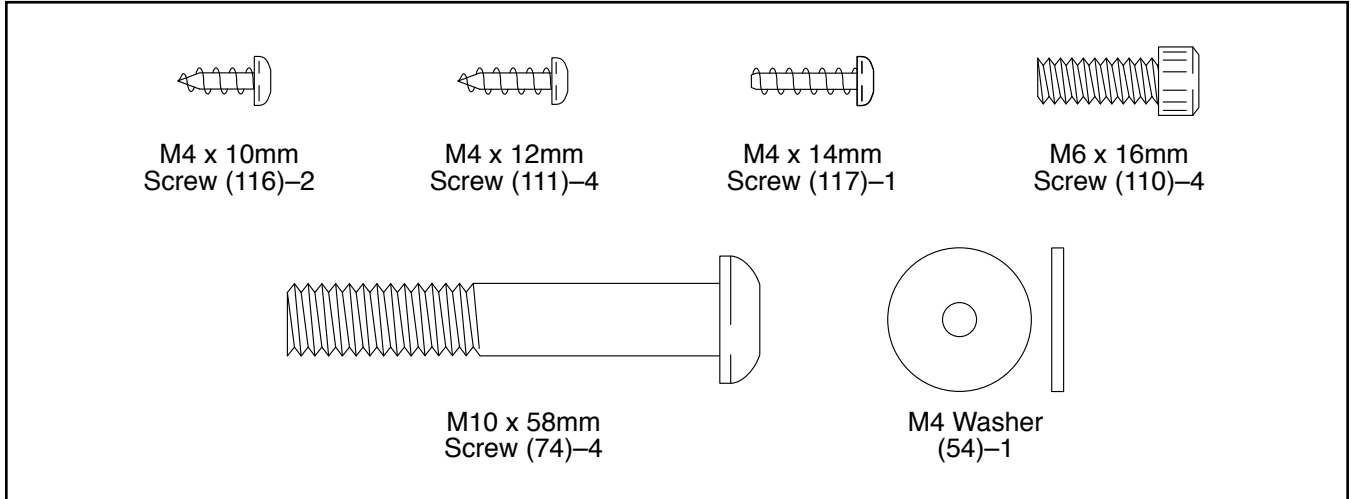

ASSEMBLY

- Assembly requires two persons.
- Place all parts in a cleared area and remove the packing materials. Do not dispose of the packing materials until you finish all assembly steps.
- Left parts are marked “L” or “Left” and right parts are marked “R” or “Right.”

- To identify small parts, see page 5.
- In addition to the included tool(s), assembly requires the following tools:

one Phillips screwdriver



Assembly may be easier if you have your own set of wrenches. To avoid damaging parts, do not use power tools.

1. Go to www.iconsupport.eu on your computer and register your product.

- activates your warranty
- saves you time if you ever need to contact Customer Service
- allows us to notify you of upgrades and offers

Note: If you do not have Internet access, call Customer Service (see the front cover of this manual) and register your product.

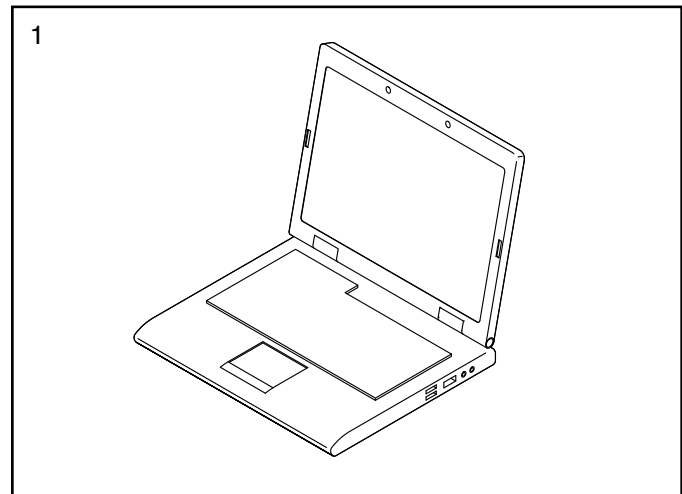

2. Remove and discard the indicated shipping insert. If there are shipping screws in the Front Stabilizer (22), remove and discard them.

Attach the Front Stabilizer (22) to the Base (1) with two M10 x 58mm Screws (74).

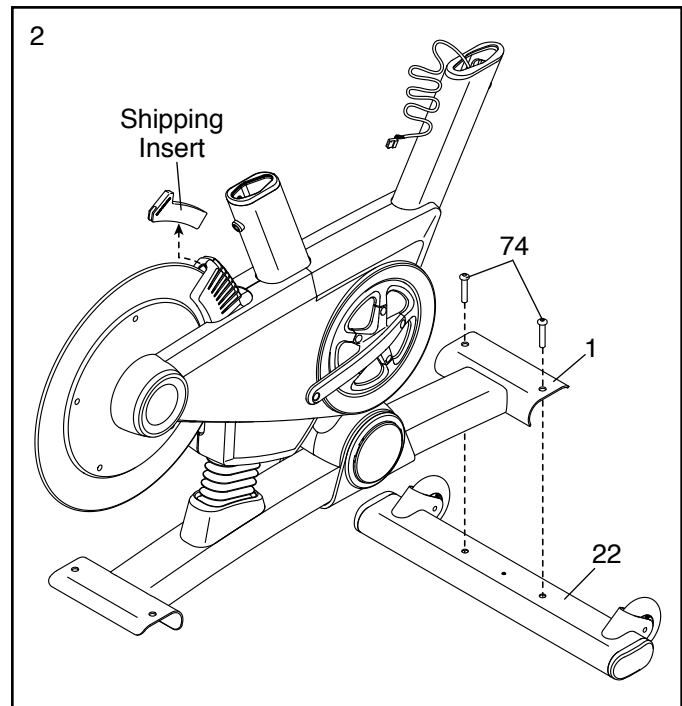

3. **If there are shipping screws in the Rear Stabilizer (23), remove and discard them.**

Attach the Rear Stabilizer (23) to the Base (1) with two M10 x 58mm Screws (74).

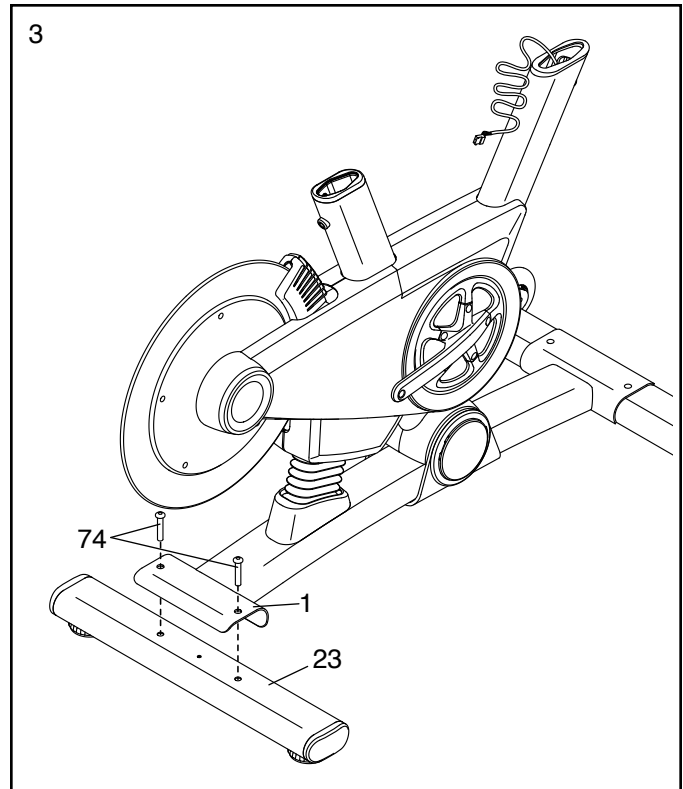

4. **See the inset drawing.** Using a plastic bag to keep your fingers clean, apply some of the included grease to the sides of the channel on the top of the Saddle Post (3).

Orient the Saddle Post (3) so that the height indicators are on the side shown.

Loosen the indicated Adjustment Screw (47), and insert the Saddle Post (3) into the Frame (2). Then, slide the Saddle Post upward or downward to the desired position, and tighten the Adjustment Screw.

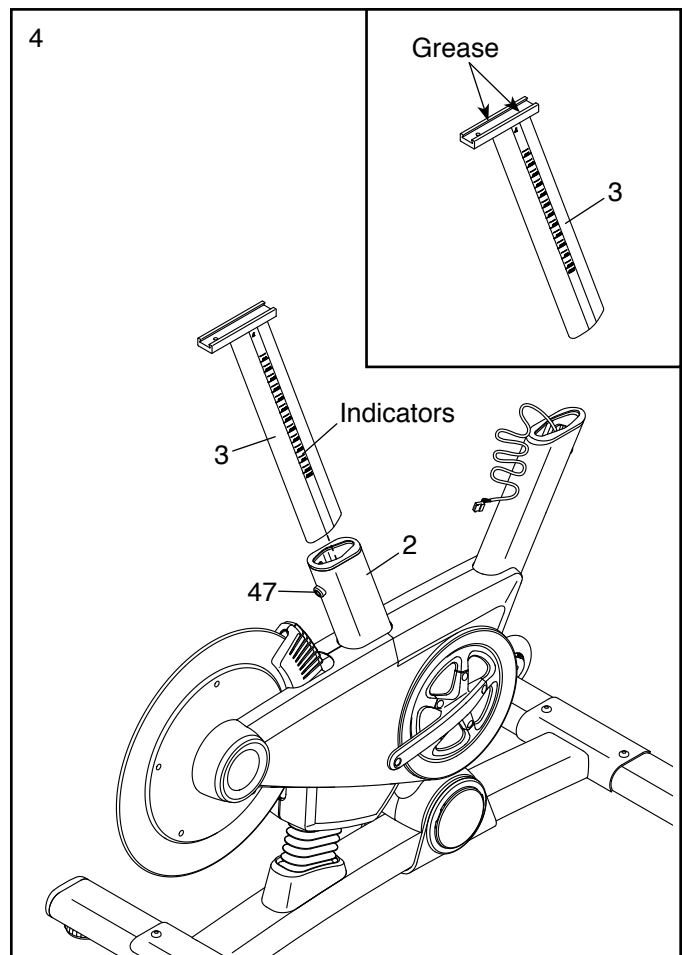

5. **Tip: You can attach your own saddle to the Saddle Carriage (4) if desired.** Loosen the attachment hardware (not shown) beneath the Saddle (5), and remove the Saddle. Then, attach your own saddle and retighten the attachment hardware.

Orient the Saddle Carriage (4) as shown.

Loosen the indicated M8 x 15mm Round Head Screw (115), and slide the Saddle Carriage (4) into the Saddle Post (3). Then, slide the Saddle Carriage to the desired position, and tighten the Round Head Screw.

Then, attach an M4 Washer (54) and the Carriage Cover (91) to the Saddle Carriage (4) with an M4 x 14mm Screw (117).

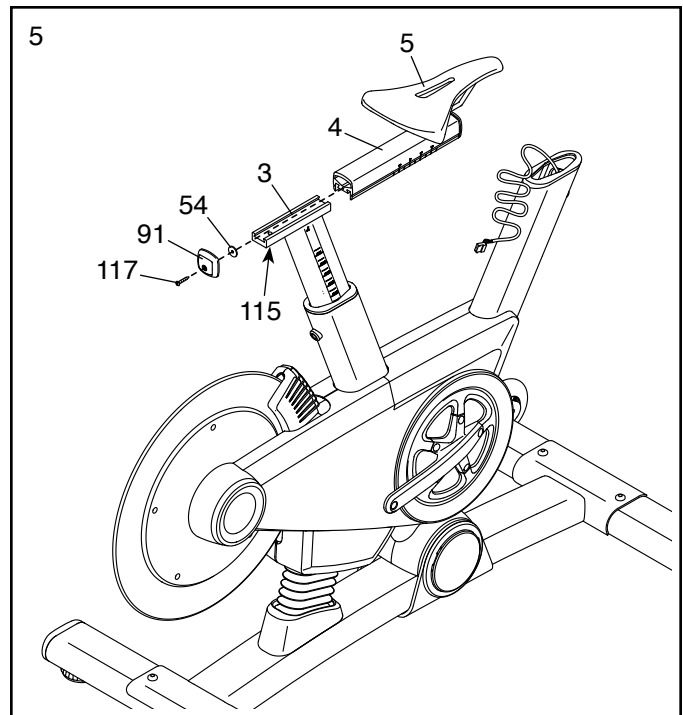

6. **See step 8. If the Handlebar Clamp (28) and four M6 x 16mm Screws (110) are preattached to the Handlebar Carriage (105), remove them and set them aside until step 8.**

Have a second person hold the Handlebar Post (6) near the Frame (2).

Locate the long wire tie in the lower end of the Handlebar Post (6). Tie the long wire tie to the Main Wire (68). Next, locate the same wire tie in the access hole in the Handlebar Carriage (105). Pull the wire tie upward until the end of the Main Wire is in the access hole.

See the inset drawing. Next, pull the upper end of the long wire tie until the Main Wire (68) is routed through the Handlebar Carriage (105) as shown. Then, untie and discard the long wire tie.

Tip: Avoid pinching the Main Wire (68). Loosen the indicated Adjustment Screw (47), and insert the Handlebar Post (6) into the Frame (2).

Move the Handlebar Post (6) upward or downward to the desired position, and tighten the Adjustment Screw (47).

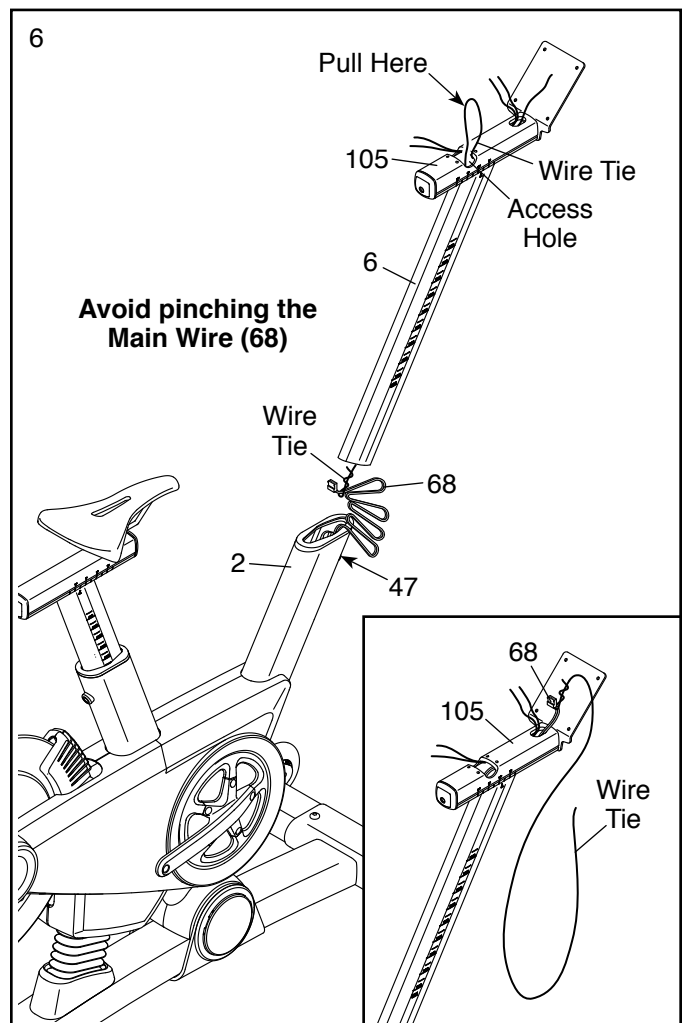

7. Have a second person hold the Handlebar (7) near the Handlebar Carriage (105).

Locate one of the remaining wire ties in the Handlebar Carriage (105). Tie the indicated end of the wire tie to the Right Extension Wire (107). Then, pull the other end of the wire tie until the Right Extension Wire is routed through the Handlebar Carriage. Then, untie and discard the wire tie.

Route the Left Extension Wire (108) through the Handlebar Carriage (105) in the same way.

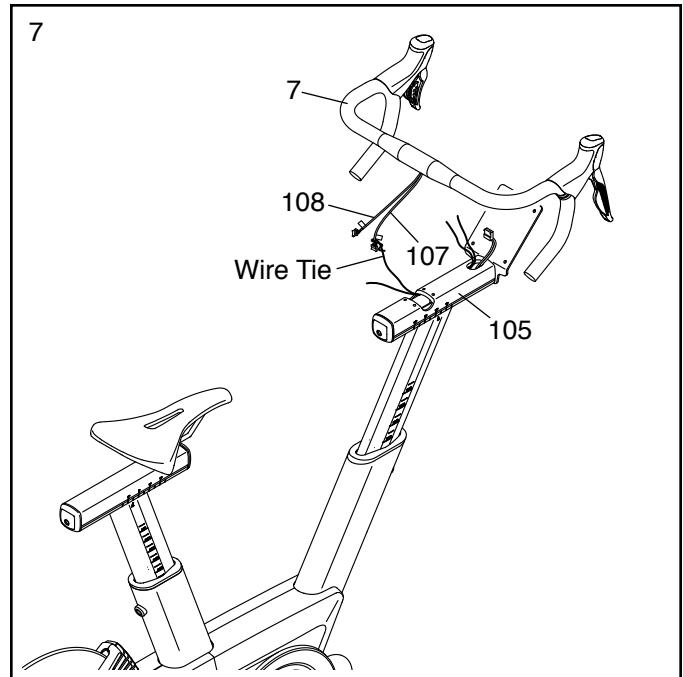

8. **Tip: Avoid pinching the wires.** Hold the Handlebar (7) on the Handlebar Carriage (105), and rotate the Handlebar to the desired angle; **make sure that the Handlebar is centered on the Handlebar Carriage.**

Attach the Handlebar (7) with the Handlebar Clamp (28) and four M6 x 16mm Screws (110); **start all four Screws, and then tighten them.**

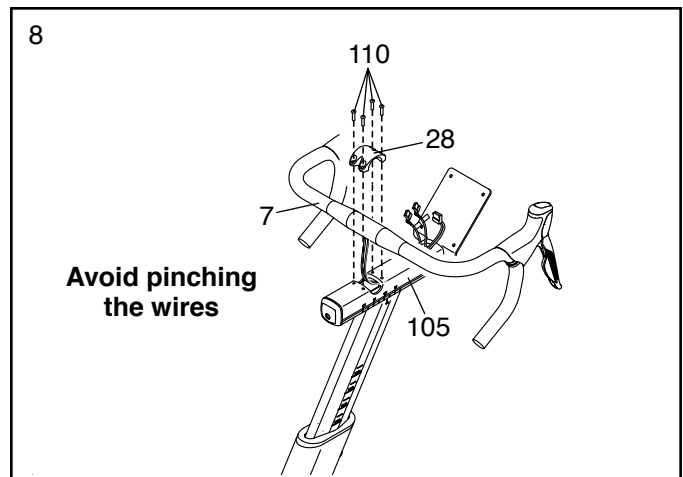

9. Have a second person hold the Console (9) near the Handlebar Carriage (105).

Connect the console wires to the Main Wire (68) and to the Extension Wires (107, 108); **make sure to connect the console wire that has an "L" tag to the Extension Wire that has an "L" tag, and connect the console wire that has an "R" tag to the Extension Wire that has an "R" tag.**

Insert the excess wire into the Console (9).

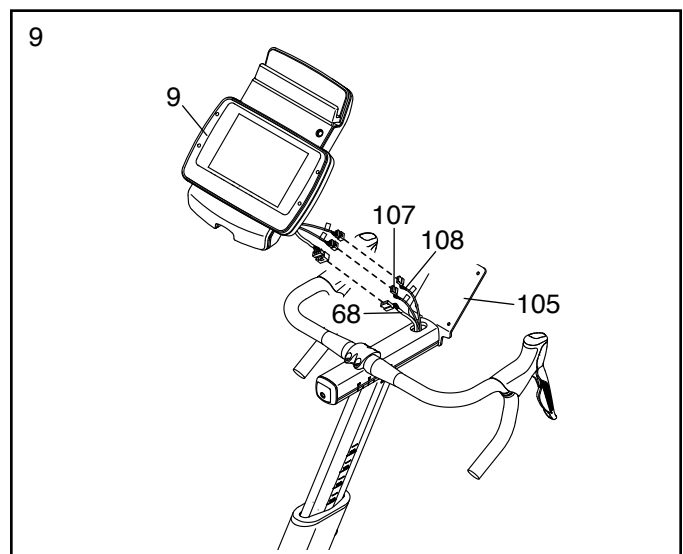

10. **Tip: Avoid pinching the wires.** Attach the Console (9) to the Handlebar Carriage (105) with four M4 x 12mm Screws (111).

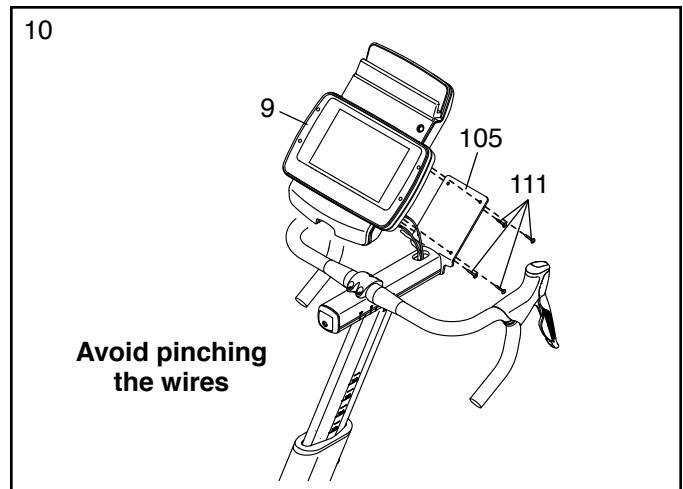

11. Attach the Tray (8) to the Frame (2) with two M4 x 10mm Screws (116).

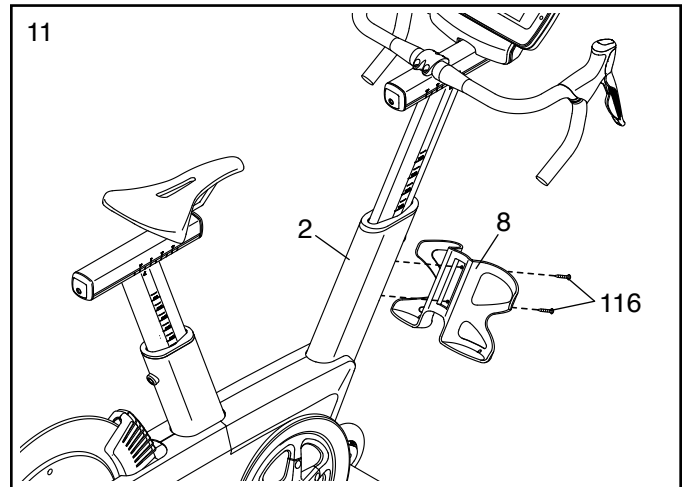

12. **Tip: You can attach your own pedals if desired.**

Identify the Right Pedal (62).

Using the included flat wrench tool, **firmly tighten** the Right Pedal (62) **clockwise** into the Right Crank Arm (64).

Firmly tighten the Left Pedal (not shown) **counterclockwise** into the Left Crank Arm (not shown).

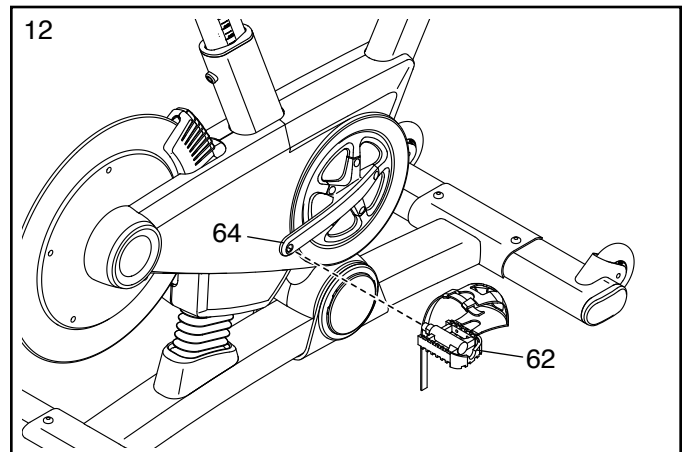

13. **After the training bike is assembled, inspect it to make sure that it is assembled correctly and that it functions properly. Make sure that all parts are properly tightened before you use the training bike.**
Note: Extra parts may be included. Place a mat beneath the training bike to protect the floor.

HOW TO USE THE TRAINING BIKE

HOW TO PLUG IN THE POWER CORD

This product must be earthed. If it should malfunction or break down, earthing provides a path of least resistance for electric current to reduce the risk of electric shock. This product's power cord has an equipment-earthing conductor and an earthing plug. **IMPORTANT: If the power cord is damaged, it must be replaced with a manufacturer-recommended power cord.**

⚠ DANGER: Improper connection of the equipment-earthing conductor can result in an increased risk of electric shock. Check with a qualified electrician or serviceman if you are in doubt as to whether the product is properly earthed. Do not modify the plug provided with the product—if it will not fit the outlet, have a proper outlet installed by a qualified electrician

Follow the steps below to plug in the power cord.

1. Plug the indicated end of the power cord into the socket on the frame.

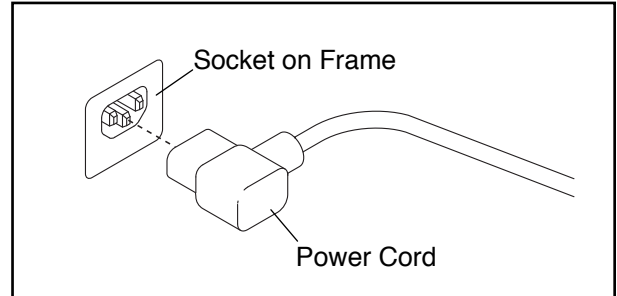

2. Plug the power cord into an appropriate outlet that is properly installed and earthed in accordance with all local codes and ordinances.

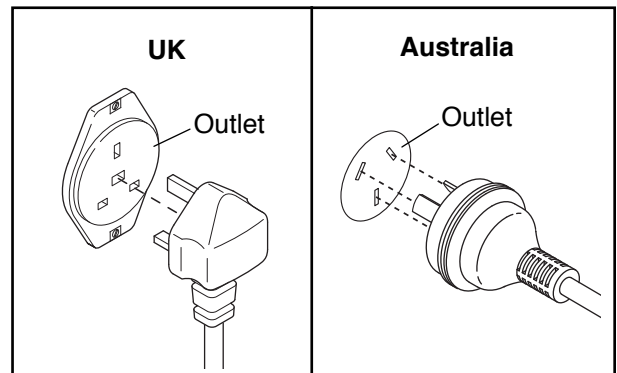

FEATURES OF THE TRAINING BIKE

Watts Measurement

Each training bike is individually calibrated to measure your power output and allow you to monitor your watts and RPMs directly on the console.

By monitoring your watts and RPMs, you can see how hard you are training and make sure that you are challenging yourself and improving.

The Incline System

The training bike can incline and decline up to 20 percent to realistically simulate outdoor terrain. When you create maps of your actual training routes on iFit.com (see the console instructions beginning on page 14 for more information), the training bike will automatically incline and decline to match the terrain of your training routes.

The Handlebar Shifters

The training bike allows you to shift gears just like you do on your road bike. The right and left handlebar shifters simulate front and rear derailleurs that you can configure to match the gearing setup of your road bike (see the console instructions beginning on page 14 for more information).

Pedaling Form Features

The training bike has multiple features to help you develop correct pedaling form:

Freewheel—The training bike has a freewheel that simulates a road bike rather than a fixed-drive spin bike. This discourages you from letting your feet coast through the top and bottom of your pedal stroke.

Flywheel—The flywheel on the training bike has the correct inertia to allow you to pedal smoothly while encouraging you to use good pedaling form.

HOW TO ADJUST THE GEOMETRY OF THE TRAINING BIKE

The training bike can be adjusted to match the geometry of your road bike to promote correct form and to ensure proper training of the muscles. **Note: Make adjustments in small increments, and then pedal the training bike to test the adjustments.**

How to Adjust the Angle of the Saddle

You can adjust the angle of the saddle to the position that is most comfortable. You can also adjust the saddle forward or backward for increased comfort or to adjust the distance to the handlebar.

To adjust the saddle, first loosen the attachment hardware beneath the saddle a few turns. Next, tilt the saddle upward or downward or slide the saddle forward or backward. Then, retighten the attachment hardware.

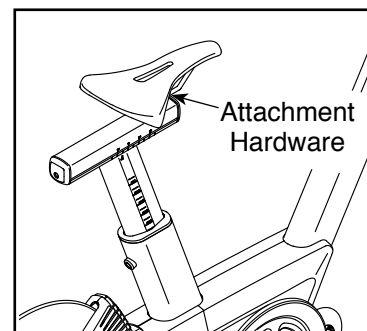

Note: You can remove the saddle and attach your own saddle if desired.

How to Adjust the Saddle Carriage

To adjust the position of the saddle carriage, loosen the adjustment screw, move the saddle carriage forward or backward, and then retighten the adjustment screw.

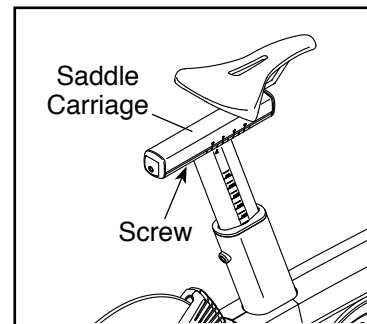

How to Adjust the Saddle Post

For effective training, the saddle should be at the proper height. As you pedal, there should be a slight bend in your knees when the pedals are in the lowest position. To adjust the height of the saddle post, loosen the adjustment screw, move the saddle post upward or downward, and then retighten the adjustment screw.

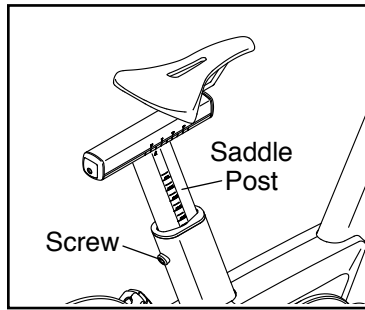

How to Adjust the Rotation of the Handlebar

To rotate the handlebar to match the position of the handlebar on your road bike, loosen the indicated screws, rotate the handlebar, and then retighten the screws.

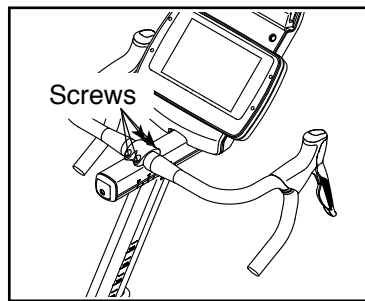

How to Adjust the Handlebar Post

To adjust the height of the handlebar post, loosen the adjustment screw, move the handlebar post upward or downward, and then retighten the adjustment screw.

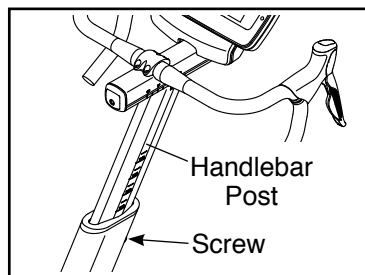

How to Adjust the Handlebar Carriage

To adjust the position of the handlebar carriage to match your road bike, loosen the indicated screws, move the handlebar carriage forward or backward, and then retighten the screws.

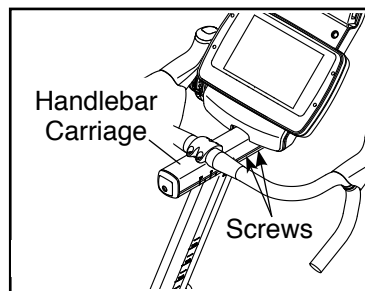

HOW TO LEVEL THE TRAINING BIKE

If the training bike rocks slightly on your floor during use, turn one or both of the leveling feet on the rear stabilizer until the rocking motion is eliminated.

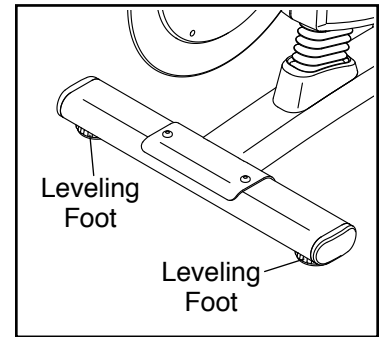

HOW TO USE THE PEDALS

To use the pedals, insert your shoes into the toe cages, and pull the ends of the toe straps. To adjust the toe straps, press and hold the tabs on the buckles, adjust the toe straps to the desired position, and then release the tabs.

Note: You can attach your own pedals to the training bike if desired.

HOW TO USE THE IPAD HOLDER

IMPORTANT: The iPad® holder is designed for use with most full-size iPads. Do not place an iPad mini or any other electronic device or object in the iPad holder.

To insert an iPad into the iPad holder, set the bottom edge of the iPad in the tray. **Make sure that the iPad is firmly secured in the iPad Holder.** Reverse these actions to remove the iPad from the iPad Holder.

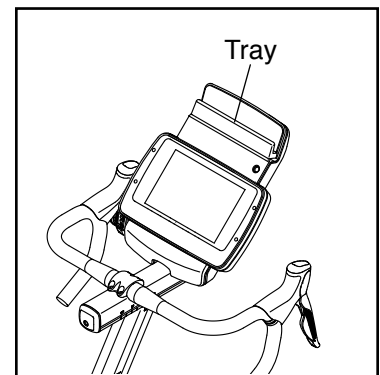

CONSOLE DIAGRAM

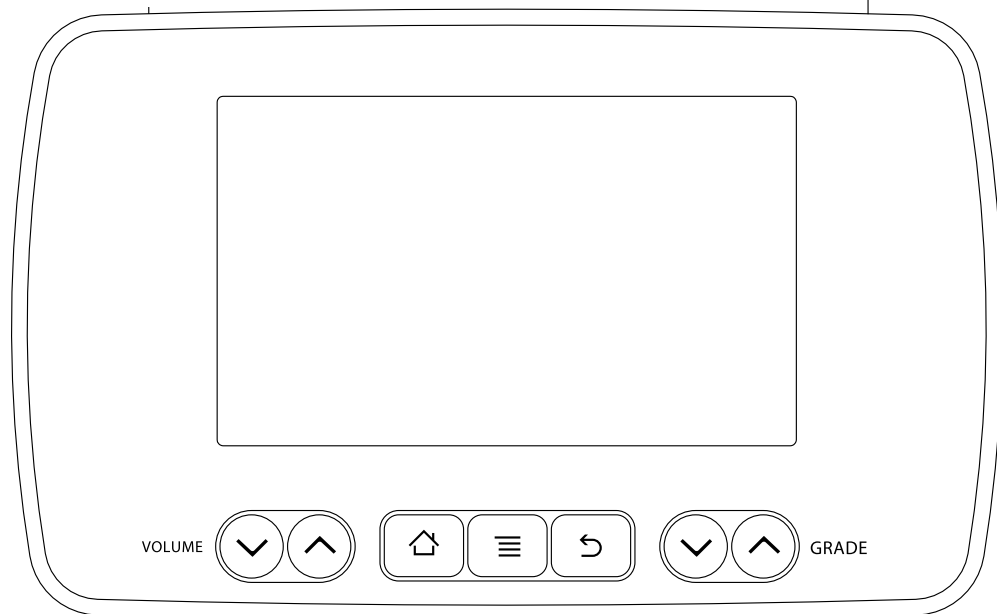

MAKE YOUR TRAINING GOALS A REALITY WITH IFIT.COM

With your new iFit-compatible training bike, you can use an array of features on iFit.com to make your training goals a reality:



Train anywhere in the world with customizable Google Maps.



Download training workouts designed to help you reach your personal goals.



Measure your progress by competing against other users in the iFit community.



Upload your workout results to the iFit cloud and track your accomplishments.



Set calorie, time, distance, or watts goals for your workouts.



Watch high-definition videos with simulated workouts.



Choose and download sets of weight-loss workouts.

Go to www.iFit.com to learn more.

FEATURES OF THE CONSOLE

The advanced console offers an array of features designed to make your workouts more effective and enjoyable.

When you use the manual mode of the console, you can change the incline (resistance) of the training bike and change gears with the touch of a button.

While you exercise, the console will display continuous exercise feedback, including watts and pedaling cadence feedback.

During your workout, you can do intervals at any time to measure your performance over short periods of time. The console will record and display your results for each interval.

You can also measure your heart rate using an optional heart rate monitor.

In addition, the console offers a selection of Le Tour de France workouts. Each workout automatically changes the incline (resistance) of the training bike to match the real terrain of the Le Tour de France bicycle race and allows you to change gears to maintain your desired pedaling cadence.

The console also features new iFit technology that enables the console to communicate with your wireless network. With iFit technology, you can download personalized workouts, create your own workouts, track your workout results, and access many other features. **See www.iFit.com for complete information.**

You can even connect your MP3 player or CD player to the console sound system and listen to your favorite music or audio books while you exercise.

To turn on the power, see this page. **To learn how to use the touch screen**, see page 16. **To set up the console**, see page 16.

HOW TO TURN ON THE POWER

IMPORTANT: If the training bike has been exposed to cold temperatures, allow it to warm to room temperature before you turn on the power. If you do not do this, you may damage the console displays or other electrical components.

Plug in the power cord (see HOW TO PLUG IN THE POWER CORD on page 11). Next, locate the power switch on the frame near the power cord. Press the power switch to the reset position.

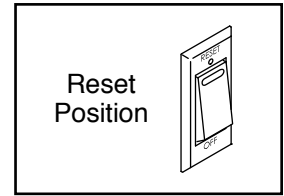

The display will then turn on and the console will be ready for use.

Note: When you turn on the power for the first time, the incline system may calibrate automatically.

The training bike will move upward and downward as it calibrates. When the training bike stops moving, the incline system is calibrated.

IMPORTANT: If the incline system does not calibrate automatically, see step 4 on page 24 and manually calibrate the incline system.

IMPORTANT: The console features a display demo mode, designed to be used if the training bike is displayed in a store. If the demo mode is turned on, the console will not turn off and the display will not be reset when you finish exercising. To turn off the demo mode, see step 8 on page 22.

HOW TO USE THE TOUCH SCREEN

The console features a tablet with a full-color touch screen. The following information will help you become familiar with the tablet's advanced technology:

- The console functions similarly to other tablets. You can slide or flick your finger against the screen to move certain images on the screen, such as the displays in a workout. However, you cannot zoom in and out by sliding your fingers on the screen.
- To type information into a text box, first touch the text box to view the keyboard. To use numbers or other characters on the keyboard, touch the ?123 button. To view more characters, touch the Alt button. Touch the Alt button again to return to the number keyboard. To return to the letter keyboard, touch the ABC button. To use a capital character, touch the button with an upward-facing arrow. To use multiple capital characters, touch the arrow button again. To return to the lowercase keyboard, touch the arrow button a third time. To clear the last character, touch the button with a backward-facing arrow and an X.

- Use these buttons on the console to navigate the tablet. Press the home button to return to the main menu. Press the center button to access the settings menu (see page 22). Press the back button to return to the previous screen.

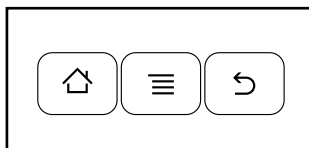

- If it is difficult for you to touch the correct buttons on the screen, the screen may not be properly calibrated. To calibrate the screen, see step 5 on page 24.

HOW TO SET UP THE CONSOLE

Before using the training bike for the first time, follow the steps below to set up the console.

1. Connect to a wireless network.

Note: To access the Internet, download iFit workouts, and use some other features of the console, the console must be connected to a wireless

network. See HOW TO USE THE WIRELESS NETWORK MODE on page 25 to connect the console to your wireless network.

2. Check for firmware updates.

First, see step 1 on page 22 and step 2 on page 24 and select the maintenance mode. Then, see step 3 on page 24 and check for firmware updates.

3. Calibrate the incline system.

First, see step 1 on page 22 and step 2 on page 24 and select the maintenance mode. Then, see step 4 on page 24 and calibrate the incline system of the training bike.

4. Create an iFit account.

On your computer, smartphone, tablet, or other Internet-capable device, open an Internet browser and go to www.iFit.com. Follow the prompts on the website to sign up for your iFit membership. If you have an activation code, select the code activation option.

The console is now ready for you to begin training. The following pages explain the various workouts and other features that the console offers.

To use the manual mode, see page 17. **To use a Le Tour de France workout**, see page 19. **To use a set-a-goal workout**, see page 20. **To use an iFit workout**, see page 21.

To use the equipment settings mode, see page 22. **To use the maintenance mode**, see page 24. **To use the wireless network mode**, see page 25. **To use the sound system**, see page 26. **To use the Internet browser**, see page 26.

Note: If there is a sheet of plastic on the display, remove the plastic.

The console can display speed and distance in either miles or kilometers. To find which unit of measurement is selected, see step 15 on page 23.

HOW TO USE THE MANUAL MODE

1. Touch the screen or begin pedaling to activate the console.

See HOW TO TURN ON THE POWER on page 15.

2. Select the main menu.

When you turn on the console, the main menu will appear on the screen after the console boots up.

Touch the home button at the bottom of the screen to return to the main menu at any time.

Touch the Start button to start a manual workout.

3. Change the incline (resistance) of the training bike as desired.

As you pedal, change the incline (resistance) of the training bike by pressing the Grade increase and decrease buttons on the console.

You can also change the incline of the training bike by pressing the shifter buttons. To increase the incline, press the front and rear buttons on the right shifter simultaneously; to decrease the incline, press the front and rear buttons on the left shifter simultaneously.

Note: After you press a button, it will take a moment for the training bike to reach the selected incline level. **You will hear the incline motor while the incline is changing. This is normal.**

CAUTION: The training bike can move through a broad range of incline levels. Hold the handlebars and be prepared for the training bike to move when you change the incline.

4. Change gears as desired.

You can set up the training bike to simulate your road bike. To select the gearing option(s) for the training bike, see step 7 on page 22.

Note: The training bike simulates gears; there are no actual gears.

Change gears by pressing the buttons on the shifters. Note: After you press a button, it will take a moment for the training bike to change to the selected gear. **To avoid damaging the shifters, do not pull on the shifters or squeeze the shifters.**

Press the buttons on the left shifter to change the front gear; press the buttons on the right shifter to change the rear gear.

On the left shifter, press the front button to increase the resistance; press the rear button to decrease the resistance.

On the right shifter, press the front button to decrease the resistance; press the rear button to increase the resistance.

The numbers of the currently selected front and rear gears will appear in the display on the screen.

5. Follow your progress.

The console offers several display modes. The display mode that you select will determine which workout information is shown.

To select the desired display mode, simply flick or slide the screen. You can also view additional workout information by touching the red boxes on the screen.

If desired, adjust the volume level by pressing the Volume increase and decrease buttons on the console.

To pause the workout, stop pedaling or touch either the back button or the home button at the bottom of the screen. To continue the workout, touch the Resume button. To end the workout session, touch the End Workout button.

When you touch the End Workout button, a workout summary will appear on the screen. After you view the workout summary, touch the Finish button to return to the main menu. You may also be able to either save or publish your results using one of the options on the screen.

6. Do intervals if desired.

During a workout, you can use the interval screen to measure your performance for short periods of time. To select the interval screen, simply flick or slide the screen.

To begin an interval, touch the Start button. To end the current interval, touch the Lap button. You can add as many intervals as desired to your workout.

The console will record data for each interval that you can view at any time during your workout. The interval screen will show a list of the recorded intervals. Scroll the screen to view data for the desired interval.

7. Wear a heart rate monitor and measure your heart rate if desired.

You can wear an optional heart rate monitor to measure your heart rate. For more information about the optional heart rate monitor, see page 26. Note: The console is compatible with ANT+™ and BLUETOOTH® Smart heart rate monitors.

When your heart beat is detected, your heart rate will be shown in the display on the screen.

8. When you are finished exercising, unplug the power cord.

When you are finished exercising, press the power switch to the off position and unplug the power cord. **IMPORTANT: If you do not do this, the electrical components of the training bike may wear prematurely.**

HOW TO USE A LE TOUR DE FRANCE WORKOUT

1. Touch the screen or begin pedaling to activate the console.

See HOW TO TURN ON THE POWER on page 15.

2. Select the main menu.

See step 2 on page 17.

3. Select a Le Tour de France workout.

To select a Le Tour de France workout, first touch the cyclist button at the bottom of the screen. The workouts menu will appear on the screen.

Next, select the Tour de France button. Then, select the desired workout. Note: It may be necessary to scroll the screen to view all the workout options.

The screen will show the name, the estimated duration, and the distance of the workout. The screen will also show the approximate number of calories you will burn during the workout and a map of the workout. Note: You may be able to select other variables for the workout on this screen.

4. Start the workout.

Touch the Start Workout button to start the workout.

The workout may have a warm-up segment. To skip the warm-up segment, touch the Skip button. To select warm-up segment options for the training bike, see step 16 on page 23.

Each workout is divided into several segments. One incline level (resistance) is programmed for each segment. Note: The same incline level may be programmed for consecutive segments.

During the workout, the screen will show a map of the route and a marker indicating your progress. Touch the buttons on the screen to select the desired map options.

The profiles display will show your progress. To view the profiles display, flick or slide the screen.

At the end of the first segment of the workout, the incline will automatically adjust to the incline level for the next segment.

When the incline changes, the resistance of the pedals will also change. To maintain a steady pedaling cadence, change gears by pressing the buttons on the shifters.

Note: You can manually override the incline settings by pressing the Grade buttons. **To return to the programmed incline settings of the workout,** touch the Follow Workout button.

Note: The calorie goal is an estimate of the number of calories that you will burn during the workout. The actual number of calories that you burn will depend on various factors such as your weight. In addition, your pedaling cadence will affect the number of calories you burn.

To pause the workout, stop pedaling or touch either the back button or the home button at the bottom of the screen. To continue the workout, touch the Resume button. To end the workout, touch the End Workout button.

The workout will continue in this way until the last segment ends. A workout summary will appear on the screen. After you view the workout summary, touch the Finish button to return to the main menu. You may also be able to either save or publish your results using one of the options on the screen.

5. Follow your progress.

See step 5 on page 17.

6. Do intervals if desired.

See step 6 on page 18.

7. Wear a heart rate monitor and measure your heart rate if desired.

See step 7 on page 18.

8. When you are finished exercising, unplug the power cord.

See step 8 on page 18.

HOW TO USE A SET-A-GOAL WORKOUT

1. Touch the screen or begin pedaling to activate the console.

See HOW TO TURN ON THE POWER on page 15.

2. Select the main menu.

See step 2 on page 17.

3. Select a set-a-goal workout.

To select a set-a-goal workout, touch the Set A Goal button on the screen.

To set a customized goal for your workout, touch the button for the desired goal. Then, touch the increase and decrease buttons on the screen to enter your goal and to select other variables for the workout. The screen will show the duration and distance of the workout, and the approximate number of calories you will burn during the workout.

4. Start the workout.

The workout may have a warm-up segment. To skip the warm-up segment, touch the Skip button. To select warm-up segment options for the training bike, see step 16 on page 23.

Touch the Start button to start the workout.

The workout will function in the same way as the manual mode (see page 17).

Note: You can manually override the incline settings by pressing the Grade buttons. **To return to the programmed incline settings of the workout,** touch the Follow Workout button.

The workout will continue until you reach the goal that you set. A workout summary will appear on the screen. After you view the workout summary, touch the Finish button to return to the main menu. You may also be able to either save or publish your results using one of the options on the screen.

Note: The calorie goal is an estimate of the number of calories that you will burn during the workout. The actual number of calories that you burn will depend on various factors, such as your weight. In addition, if you manually change gears or the incline during the workout, the number of calories you burn will be affected.

5. Follow your progress.

See step 5 on page 17.

6. Do intervals if desired.

See step 6 on page 18.

7. Wear a heart rate monitor and measure your heart rate if desired.

See step 7 on page 18.

8. When you are finished exercising, unplug the power cord.

See step 8 on page 18.

HOW TO USE AN iFIT WORKOUT

Note: To use an iFit workout, you must have access to a wireless network (see HOW TO USE THE WIRELESS NETWORK MODE on page 25). An iFit account is also required.

1. Touch the screen or begin pedaling to activate the console.

See HOW TO TURN ON THE POWER on page 15.

2. Select the main menu.

See step 2 on page 17.

3. Log in to your iFit account.

If you have not already done so, touch the Login button to log in to your iFit account. The screen will ask for your iFit.com username and password. Enter them and touch the Login button. Touch the Cancel button to exit the login screen. Note: Usernames and passwords are case-sensitive.

To switch users within your iFit account, touch the user button at the bottom of the screen. If more than one user is associated with the account, a list of users will appear. Touch the name of the desired user.

4. Select an iFit workout.

To download an iFit workout in your schedule, touch the Map, Train, Video, or Lose Wt. button to download the next workout of that type in your schedule. Note: You may be able to access demo workouts through these options, even if you do not log in to an iFit account.

To compete in a race that you have previously scheduled, touch the Compete button. To view your Workout History, touch the Track button. To use a set-a-goal workout, touch the Set A Goal button (see page 20).

Before some workouts will download, you must add them to your schedule on iFit.com.

For more information about the iFit workouts, please see www.iFit.com.

When you select an iFit workout, the screen will show the name, the estimated duration, and the distance of the workout. The screen will also show the approximate number of calories you will burn during the workout. If you select a competition workout, the display will count down to the beginning of the race.

5. Start the workout.

See step 4 on page 19.

An audio coach may guide you through some workouts (see HOW TO USE THE SOUND SYSTEM on page 26).

Note: You can manually override the incline settings by pressing the Grade buttons. **To return to the programmed incline settings of the workout,** touch the Follow Workout button.

6. Follow your progress.

See step 5 on page 17. The screen may also show a map of the trail you are walking or running. Touch the buttons on the screen to select the desired map options.

During a competition workout, the screen will show the speeds of the racers and the distances they have traveled. The screen will also show the numbers of seconds that the other racers are ahead of you or behind you.

7. Do intervals if desired.

See step 6 on page 18.

8. Wear a heart rate monitor and measure your heart rate if desired.

See step 7 on page 18.

9. When you are finished exercising, unplug the power cord.

See step 8 on page 18.

For more information about iFit, go to www.iFit.com.

HOW TO USE THE EQUIPMENT SETTINGS MODE

1. Select the settings main menu.

Turn on the console and select the main menu (see steps 1 and 2 on page 17). Then, touch the gears button at the bottom of the screen to select the settings main menu.

Note: You can also press the center button on the console to access the settings main menu.

2. Select the equipment settings mode.

In the settings main menu, touch the Equipment Settings button.

Note: It may be necessary to scroll the screen to view all the menu options.

3. Enable or disable the auto relogin feature.

Enable this feature to have the console automatically log in to your iFit account when you turn on the power. Note: This feature is recommended for private owners of the training bike only.

To enable or disable the auto relogin feature, first touch the Auto Relogin button. Next, touch the Enable checkbox or the Disable checkbox. Then, touch the back button on the screen.

4. Enable or disable automatic console updates.

To enable or disable automatic console updates, first touch the Auto Update button. Next, touch the Enable checkbox or the Disable checkbox. Then, touch the back button on the screen.

Note: To select a time for automatic console updates, see step 14.

5. Enable or disable the Internet browser.

To enable or disable the Internet browser, first touch the Browser button. Next, touch the Enable checkbox or the Disable checkbox. Then, touch the back button on the screen.

6. Select a time for the cadence timeout.

The console features a cadence timeout feature; if no buttons are touched or pressed and the pedals do not move for a set amount of time, the console will prompt you to resume or end the workout.

To select the amount of time the console will wait before it prompts you to resume or end the workout, touch the Cadence Timeout button and select the desired time. Then, touch the back button on the screen.

7. Select the gearing options.

The gearing on the training bike can be set up to simulate a variety of gearing options used on road bikes.

To select a front gearing option, first touch the Choose Front Gears button. Next, select the desired front gearing option for the training bike. Then, touch the back button on the screen.

To select a rear gearing option, first touch the Choose Rear Gears button. Next, select the desired rear gearing option for the training bike. Then, touch the back button on the screen.

IMPORTANT: For detailed information about gearing options, consult a road cycling book or other road cycling resource.

8. Turn on or turn off the display demo mode.

The console features a display demo mode, designed to be used if the training bike is displayed in a store. While the demo mode is turned on, the screen will show a demo presentation.

To turn on or turn off the display demo mode, first touch the Demo Mode button. Next, touch the On checkbox or the Off checkbox. Then, touch the back button on the screen.

9. Hide or display the gears button.

The console features an option to hide the gears button to prevent unauthorized users from accessing the settings main menu.

To hide or display the gears button, touch the Hide Settings button and select the desired checkbox. Then, follow the prompts on the screen.

IMPORTANT: To access the settings main menu when the gears button is hidden, draw a square clockwise on the screen.

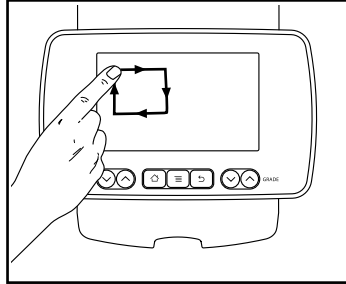

10. Select a language.

To select a language, touch the Language button and select the desired language. Then, follow the prompts on the screen. Note: This feature may not be enabled.

11. Enable or disable a passcode.

The console features a child safety passcode, designed to prevent unauthorized users from using the training bike.

To enable or disable a passcode, touch the Passcode button. To enable a passcode, touch the Enable checkbox. Then, enter a 4-digit passcode of your choice. Touch the Save button to use this passcode. Touch the Cancel button to return to the equipment settings mode and not use a passcode. To disable the passcode, touch the Disable checkbox. Then, touch the back button on the screen.

Note: If a passcode is enabled, the console will regularly ask for you to enter the passcode. The console will remain locked until the correct passcode is entered. **IMPORTANT: If you forget your passcode, enter the following master passcode to unlock the console: 1985.**

12. Enable or disable street view.

During some workouts, the screen may show a map. To enable or disable the street view feature of the maps, first touch the Street View button. Next, touch the Enable checkbox or the Disable checkbox. Then, touch the back button on the screen.

13. Select a time zone.

To select a time zone, touch the Timezone button and select the desired time zone. Then, touch the back button on the screen.

14. Select an update time.

To select a time for automatic console updates, touch the Update Time button and select the desired time. Then, touch the back button on the screen.

When you select an update time, you must also enable automatic console updates (see step 4).

IMPORTANT: You must still unplug the power cord after using your training bike. Set the update time for a time when you normally use your training bike and will be available to unplug the power cord after an update.

15. Select the unit of measurement.

Touch the US/Metric button to view the selected unit of measurement. Next, touch the checkbox for the desired unit of measurement. Then, touch the back button on the screen.

16. Select a warm-up segment option.

When you select a workout, there may be a warm-up segment before the workout begins. To select a time for the warm-up segment or to disable the warm-up segment, touch the Warm Up Time button and select the desired option. Then, touch the back button on the screen.

17. Exit the equipment settings mode.

To exit the equipment settings mode, touch the back button on the screen.

HOW TO USE THE MAINTENANCE MODE

1. Select the settings main menu.

See step 1 on page 22.

2. Select the maintenance mode.

In the settings main menu, touch the Maintenance button to enter the maintenance mode.

The maintenance mode main screen will show information about the console and the wireless network.

3. Update the console firmware.

For the best results, regularly check for firmware updates.

Touch the Firmware Update button to check for firmware updates using your wireless network. The update will begin automatically. Note: If there are no firmware updates available, touch the back button on the screen.

IMPORTANT: To avoid damaging the training bike, do not turn off the power while the firmware is being updated.

The screen will show the progress of the update. When the update is complete, the training bike will turn off and then turn back on. If it does not, press the power switch into the off position. Wait for several seconds, and then press the power switch into the reset position. Note: It may take a few minutes for the console to be ready for use.

Note: Occasionally, a firmware update may cause your console to function slightly differently. These updates are always designed to improve your training experience.

4. Calibrate the incline system of the training bike.

Touch the Calibrate Incline button. Then, touch the Begin button to calibrate the incline system.

The training bike will automatically rise to the maximum incline level, lower to the minimum incline level, and then return to the starting position. This will calibrate the incline system.

IMPORTANT: Keep pets, feet, and other objects away from the training bike while the incline system is calibrating.

When the incline system is calibrated, touch the back button on the screen.

5. Calibrate the screen.

If the screen is not properly calibrated, it will be difficult for you to touch the correct buttons on the screen. To calibrate the screen, touch the Calibrate Screen button. A small target will appear on the screen.

Using a pencil eraser or other small object, touch the center of the target. Then, touch the rest of the targets. After several seconds, the console will exit the screen calibration mode. Note: This feature may not be enabled.

6. View machine information.

Touch the Machine Info button to view information about your training bike. After you view the information, touch the back button on the screen.

7. Find keycodes.

This option is intended to be used by service technicians to identify whether a certain button is working correctly.

8. Enter a custom IP address.

If your network does not automatically generate IP addresses, touch the Custom IP button to enter a custom IP address. Note: This feature may not be enabled.

9. Exit the maintenance mode.

To exit the maintenance mode, touch the back button on the screen.

HOW TO USE THE WIRELESS NETWORK MODE

The console features a wireless network mode that allows you to set up a wireless network connection.

Note: You must have your own wireless network and an 802.11b/g/n router with SSID broadcast enabled (hidden networks are not supported).

1. Select the settings main menu.

See step 1 on page 22.

2. Select the wireless network mode.

In the settings main menu, touch the Network Setup button to enter the wireless network mode.

Note: You can also touch the wireless symbol button at the bottom of the screen to enter the wireless network mode.

3. Enable Wi-Fi.

Make sure that the Wi-Fi checkbox is marked with a green checkmark. If it is not, touch the Wi-Fi menu option once and wait for a few seconds. The console will search for available wireless networks.

4. Set up and manage a wireless network connection.

When Wi-Fi is enabled, the screen will show a list of available networks. Note: It may take several seconds for the list of wireless networks to appear.

Make sure that the checkbox on the Network notification menu option is marked with a green checkmark to have the console notify you when a wireless network is within range and available.

When a list of networks appears, touch the desired network. Note: You will need to know your network name (SSID). If your network has a password, you will also need to know the password.

An information box will ask if you want to connect to the wireless network. Touch the Connect button to connect to the network or touch the Cancel button to return to the list of networks. If the network has a password, touch the password entry box. A keyboard will appear on the screen. To view the password as you type it, touch the Show Password checkbox.

To use the keyboard, see HOW TO USE THE TOUCH SCREEN on page 16.

The Wi-Fi menu option will inform you when the console is connected to your wireless network.

To disconnect from a wireless network, select the wireless network and then touch the Forget button.

If you are having problems connecting to an encrypted network, make sure that your password is correct. Note: Passwords are case-sensitive.

Note: The iFit mode supports unsecured and secured (WEP, WPA, and WPA2) encryption. A broadband connection is recommended; performance depends on connection speed.

Note: If you have questions after following these instructions, go to www.support.iFit.com for assistance.

5. Exit the wireless network mode.

To exit the wireless network mode, touch the back button on the screen.

HOW TO USE THE SOUND SYSTEM

To play music or audio books through the console sound system while you exercise, plug a 3.5 mm male to 3.5 mm male audio cable (not included) into the jack on the console and into a jack on your MP3 player, CD player, or other personal audio player; **make sure that the audio cable is fully plugged in. Note: To purchase an audio cable, see your local electronics store.**

Next, press the play button on your personal audio player. Adjust the volume level using the Volume increase and decrease buttons on the console or the volume control on your personal audio player.

If you are using a personal CD player and the CD skips, set the CD player on the floor or another flat surface instead of on the console.

HOW TO USE THE INTERNET BROWSER

Note: To use the Internet browser, you must have access to a wireless network including a wireless router (802.11b/g/n) with SSID broadcast enabled (hidden networks are not supported).

To open the Internet browser, touch the globe button at the bottom of the screen. Then, select a website.

To navigate the Internet browser, touch the Back, Refresh, and Forward buttons on the screen. To exit the Internet browser, touch the Return button on the screen.

To use the keyboard, see HOW TO USE THE TOUCH SCREEN on page 16.

To enter a different web address in the URL bar, first, slide your finger down the screen to view the URL bar, if necessary. Then, touch the URL bar, use the keyboard to enter the address, and touch the Go button.

Note: While you are using the Internet browser, the incline, gear, and volume buttons will still function, but other buttons will not function.

Note: If you have questions after following these instructions, go to www.support.iFit.com for assistance.

THE OPTIONAL HEART RATE MONITOR

Whether your goal is to burn fat or to strengthen your cardiovascular system, the key to achieving the best results is to maintain the proper heart rate during your workouts.

The optional chest heart rate monitor will enable you to continuously monitor your heart rate while you exercise, helping you to reach your personal fitness goals. **To purchase a chest heart rate monitor, please see the front cover of this manual.**

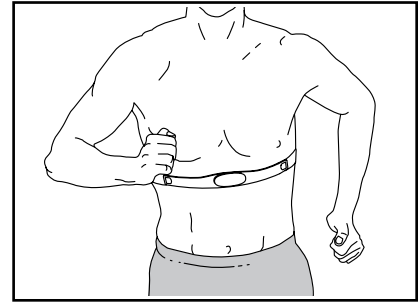

MAINTENANCE AND TROUBLESHOOTING

HOW TO MAINTAIN THE TRAINING BIKE

Inspect and tighten all parts of the training bike regularly. Replace any worn parts immediately.

To clean the training bike, use a damp cloth and a small amount of mild detergent. **IMPORTANT: To avoid damage to the console, keep liquids away from the console and keep the console out of direct sunlight.**

HOW TO CALIBRATE THE SCREEN

If it is difficult for you to touch the correct buttons on the screen, the screen may not be properly calibrated. To calibrate the screen, see step 5 on page 24.

HOW TO ADJUST THE DRIVE BELT

If the pedals slip while you are pedaling, the drive belt may need to be adjusted.

To adjust the drive belt, first **press the power switch to the off position and unplug the power cord.**

Next, locate the access hole in the underside of the Right Shield (12). Using a hex key, tighten the Idler Adjustment Screw (39) until the drive belt (not shown) is tight.

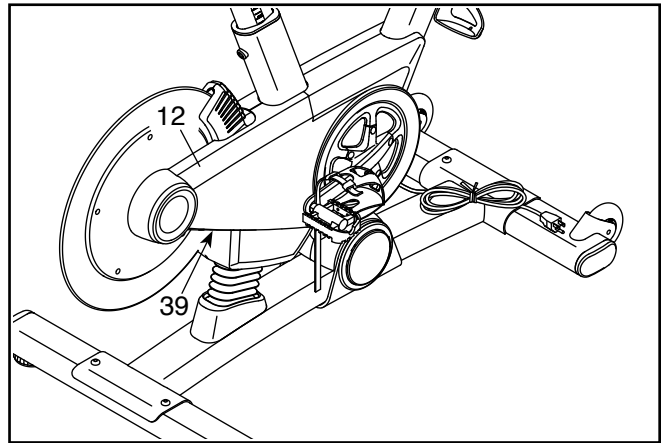

EXERCISE GUIDELINES

⚠️ WARNING: Before beginning this or any exercise program, consult your physician. This is especially important for persons over age 35 or persons with pre-existing health problems.

These guidelines will help you to plan your exercise program. For detailed exercise information, obtain a reputable book or consult your physician. Remember, proper nutrition and adequate rest are essential for successful results.

EXERCISE INTENSITY

Whether your goal is to burn fat or to strengthen your cardiovascular system, exercising at the proper intensity is the key to achieving results. You can use your heart rate as a guide to find the proper intensity level. The chart below shows recommended heart rates for fat burning and aerobic exercise.

165	155	145	140	130	125	115	♥️
145	138	130	125	118	110	103	♥️
125	120	115	110	105	95	90	♥️
<hr/>							
20	30	40	50	60	70	80	

To find the proper intensity level, find your age at the bottom of the chart (ages are rounded off to the nearest ten years). The three numbers listed above your age define your “training zone.” The lowest number is the heart rate for fat burning, the middle number is the heart rate for maximum fat burning, and the highest number is the heart rate for aerobic exercise.

Burning Fat—To burn fat effectively, you must exercise at a low intensity level for a sustained period of time. During the first few minutes of exercise, your body uses carbohydrate calories for energy. Only after the first few minutes of exercise does your body begin to use stored fat calories for energy. If your goal is to burn fat, adjust the intensity of your exercise until your heart rate is near the lowest number in your training zone. For maximum fat burning, exercise with your heart rate near the middle number in your training zone.

Aerobic Exercise—If your goal is to strengthen your cardiovascular system, you must perform aerobic exercise, which is activity that requires large amounts of oxygen for prolonged periods of time. For aerobic exercise, adjust the intensity of your exercise until your heart rate is near the highest number in your training zone.

HOW TO MEASURE YOUR HEART RATE

To measure your heart rate, exercise for at least four minutes. Then, stop exercising and place two fingers on your wrist as shown. Take a six-second heartbeat count, and multiply the result by 10 to find your heart rate. For example, if your six-second heartbeat count is 14, your heart rate is 140 beats per minute.

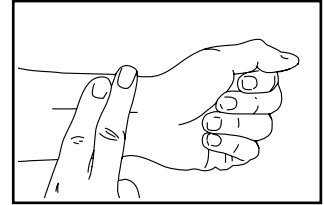

WORKOUT GUIDELINES

Warming Up—Start with 5 to 10 minutes of stretching and light exercise. A warm-up increases your body temperature, heart rate, and circulation in preparation for exercise.

Training Zone Exercise—Exercise for 20 to 30 minutes with your heart rate in your training zone. (During the first few weeks of your exercise program, do not keep your heart rate in your training zone for longer than 20 minutes.) Breathe regularly and deeply as you exercise; never hold your breath.

Cooling Down—Finish with 5 to 10 minutes of stretching. Stretching increases the flexibility of your muscles and helps to prevent post-exercise problems.

EXERCISE FREQUENCY

To maintain or improve your condition, complete three workouts each week, with at least one day of rest between workouts. After a few months of regular exercise, you may complete up to five workouts each week, if desired. Remember, the key to success is to make exercise a regular and enjoyable part of your everyday life.

PART LIST

Model No. PFEVEX71413.3 R0714A

Key No.	Qty.	Description	Key No.	Qty.	Description
1	1	Base	51	1	Board Bracket
2	1	Frame	52	4	Standoff
3	1	Saddle Post	53	1	Crank/Torque Pulley
4	1	Saddle Carriage	54	3	M4 Washer
5	1	Saddle	55	8	Magnet
6	1	Handlebar Post	56	1	Crank Screw
7	1	Handlebar	57	2	Bearing
8	1	Tray	58	1	Push Nut
9	1	Console	59	2	Frame Bushing
10	1	Upper Shield	60	1	Pivot Axle
11	1	Left Shield	61	1	Left Pedal
12	1	Right Shield	62	1	Right Pedal
13	2	Shield Cover	63	1	Left Crank Arm
14	1	Right Magnet Cover	64	1	Right Crank Arm
15	1	Left Magnet Cover	65	2	Handlebar Cap
16	1	Left Frame Cover	66	1	Drive Belt
17	1	Right Frame Cover	67	1	Power Cord
18	1	Base Shield	68	1	Main Wire
19	1	Flex Cover	69	1	Left Handlebar Post Sleeve
20	2	Cover Mount	70	1	Left Shifter/Wire
21	2	Base Cover	71	3	3/8" Jam Nut
22	1	Front Stabilizer	72	2	1/2" Washer
23	1	Rear Stabilizer	73	2	1/2" x 1" Screw
24	4	Stabilizer Cap	74	4	M10 x 58mm Screw
25	2	Leveling Foot	75	2	5/16" x 1 3/4" Bolt
26	2	Foot	76	2	5/16" Locknut
27	2	Wheel	77	1	M10 x 35mm Hex Screw
28	1	Handlebar Clamp	78	2	Post Brake
29	2	Crank Cover	79	5	M8 x 17mm Screw
30	1	Lift Motor	80	1	Clamp
31	1	Resistance Motor	81	1	Right Shifter/Wire
32	1	Resistance Magnet	82	5	#10 x 12mm Flat Head Screw
33	1	Arm	83	1	1/4" x 125mm Flat Head Screw
34	1	Magnet Axle	84	4	Wheel Spacer
35	1	Right Saddle Post Sleeve	85	2	M10 Washer
36	1	Left Saddle Post Sleeve	86	2	M8 x 15mm Screw
37	1	Idler Pulley	87	2	Lift Motor Bushing
38	1	Idler Bolt	88	1	Magnet Spring
39	1	Idler Adjustment Screw	89	5	M4 x 16mm Bright Screw
40	1	Flywheel Ring	90	2	Friction Fastener
41	1	Flywheel Hub	91	3	Carriage Cover
42	1	Flywheel Axle	92	1	Saddle Mount Assembly
43	1	Flywheel Spacer	93	2	#8 Star Washer
44	1	Thrust Washer	94	2	M4 x 16mm Screw
45	1	Flywheel Pulley	95	10	#8 x 1/2" Self-tapping Screw
46	1	Right Handlebar Post Sleeve	96	4	M4 x 12mm Flange Screw
47	2	Adjustment Screw	97	7	M4 x 19mm Screw
48	1	Power Switch	98	1	Electronics Shield
49	1	Grommet	99	2	1/4" Nut
50	1	Control Board	100	1	M10 Locknut

Key No.	Qty.	Description	Key No.	Qty.	Description
101	1	Reed Switch/Wire	114	4	#8 x 1/2" Bright Screw
102	1	Crank Hub	115	3	M8 x 15mm Round Head Screw
103	10	Crank Spacer	116	2	M4 x 10mm Screw
104	4	M8 Locknut	117	3	M4 x 14mm Screw
105	1	Handlebar Carriage	118	5	M8 x 30mm Screw
106	5	M8 x 20mm Screw	*	–	Lift Motor Wire
107	1	Right Extension Wire	*	–	Resistance Motor Wire
108	1	Left Extension Wire	*	–	Blue Wire
109	10	M4 x 9mm Screw	*	–	Green Wire
110	4	M6 x 16mm Screw	*	–	White Wire
111	4	M4 x 12mm Screw	*	–	Grease Packet
112	1	Crank	*	–	Assembly Tool
113	2	#8 x 1/2" Screw	*	–	User's Manual

Note: Specifications are subject to change without notice. For information about ordering replacement parts, see the back cover of this manual. *These parts are not illustrated.

EXPLODED DRAWING

Model No. PFEVEX71413.3 R0714A

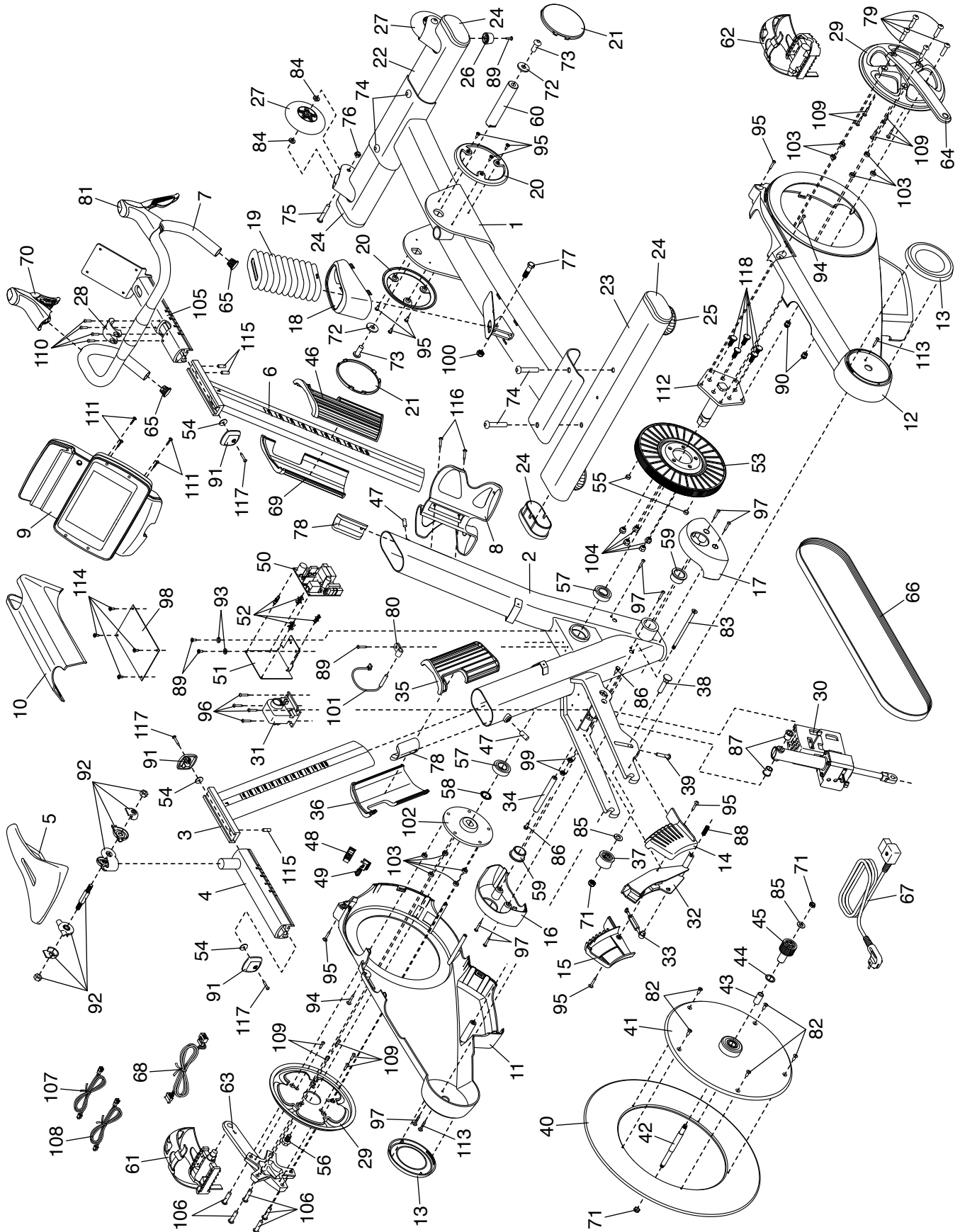

ORDERING REPLACEMENT PARTS

To order replacement parts, please see the front cover of this manual. To help us assist you, be prepared to provide the following information when contacting us:

- the model number and serial number of the product (see the front cover of this manual)
- the name of the product (see the front cover of this manual)
- the key number and description of the replacement part(s) (see the PART LIST and the EXPLODED DRAWING near the end of this manual)

RECYCLING INFORMATION

This electronic product must not be disposed of in municipal waste. To preserve the environment, this product must be recycled after its useful life as required by law.

Please use recycling facilities that are authorized to collect this type of waste in your area. In doing so, you will help to conserve natural resources and improve European standards of environmental protection. If you require more information about safe and correct disposal methods, please contact your local city office or the establishment where you purchased this product.

